

CH03-BH060-A : SIM CARD HOLDER SMT 6 CONTACTS WITH SWITCH

FEATURES

1. GENERAL CHARACTERISTICS

DIMENSIONS: 29.70L x 17.20W x 2.50H mm
 OPERATING POSITION: SHAFT UP / DOWN / HORIZONTAL
 MOUNTING SYSTEM: SMT TYPE
 DURABILITY: 5,000 CYCLES
 OPERATION TEMPERATURE: -25°C TO +85°C

2. MECHANICAL CHARACTERISTICS

INSULATION MATERIAL: THERMOPLASTIC, UL 94V-0
 CONTACT MATERIAL: PHOSPHOR BRONZE
 CONTACT PLATING: GOLD ON CONTACT AREA, TIN ON SOLDER TAIL

3. ELECTRICAL CHARACTERISTICS

CONTACT RESISTANCE: 30M OHMS MAX.
 INSULATION RESISTANCE: > 1000M OHMS MIN. / 500V DC
 RATED CURRENT: 0.5A MAX.
 RATED VOLTAGE: 30V AC
 WITHSTANDING DIELECTRIC VOLTAGE: 500V AC R.M.S. FOR 1 MINUTE

4. SOLDERABILITY

MAX. PROCESSING TEMP.: 260°C FOR 10 SEC.

NOTES:

1. ACCEPTABLE SIM CARD SIZE SHOULD MEET GSM 11.11 SPECIFICATION REQUIREMENT \triangle

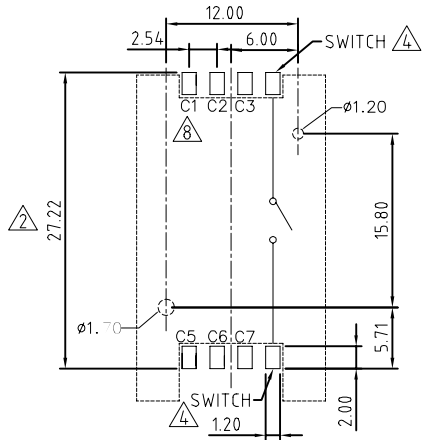
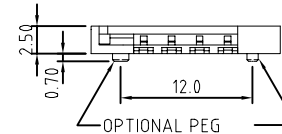
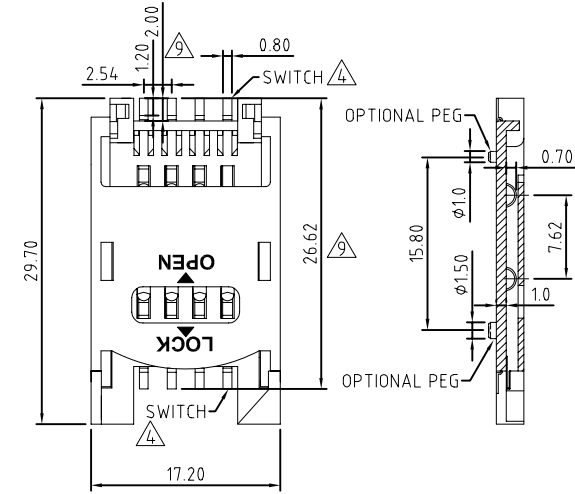
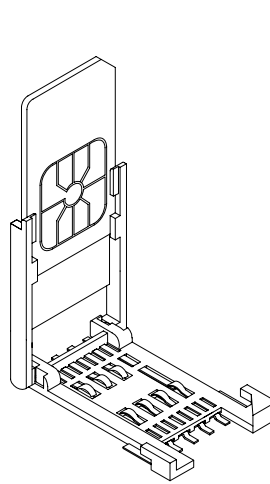

RECOMMENDED PCB LAYOUT

HOW TO ORDER

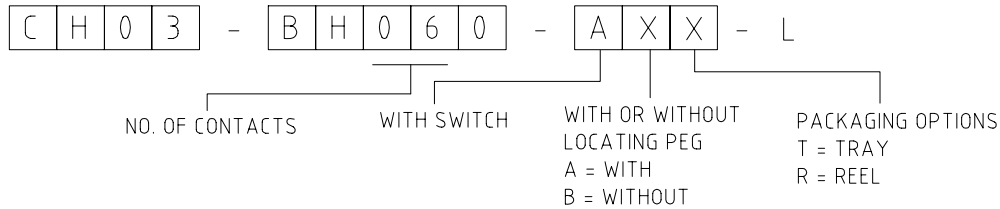

REV.	DATE	DRN
10	07/07/03	- NYW RELEASE
11	12/11/04	- NYW
12	04/02/04	- NYW
13	21/03/06	- NYW
14	30/06/05	- NYW
15	14/07/06	- NYW
16	29/05/07	- NYW
17	04/06/08	- NYW
18	30/06/08	- CHC
19	18/03/09	- CHC
20	28/04/09	- CHC

1	REMOVE NON-ROHS VERSION
2	ADD NOTES 1
3	ADD ELECTRICAL SPEC.
4	DESIGNATE PIN 1
5	ADD DIMENSIONS
6	PACKAGING DRAWING ADDED

Scale:	2:1
Drawn:	CHC
App'd:	XXXX
Date:	18 MAR '09

THIRD ANGLE	
Title	SIM CARD ACCEPTOR
Revision:	2.0

Unstated Tolerances:	0 Dec Places 1 Dec Places 2 Dec Places 3 Dec Places
Material	SEE NOTE
	NOT TO SCALE
Unit:	mm

Material	SEE NOTE
	NOT TO SCALE
Unit:	mm

THIS DRAWING IS CONFIDENTIAL AND MUST NOT BE COPIED OR DISCLOSED WITHOUT WRITTEN CONSENT

Type:	CH03-BH
	CH03-BH060-A
Drawing Number:	
Sheet	1 of 3
Drawing	Circle E and O E

CH03-BH0X0-XXT-L - TRAY PACKAGING DRAWING

PACKING CONDITION

TRAY×10 (110PCS/TRAY)

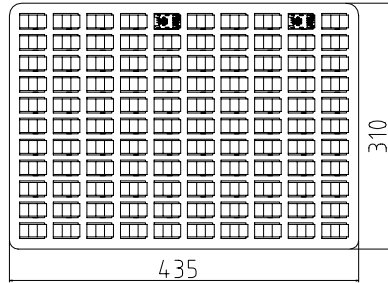

INNER BOX×5 (1100PCS/BOX)

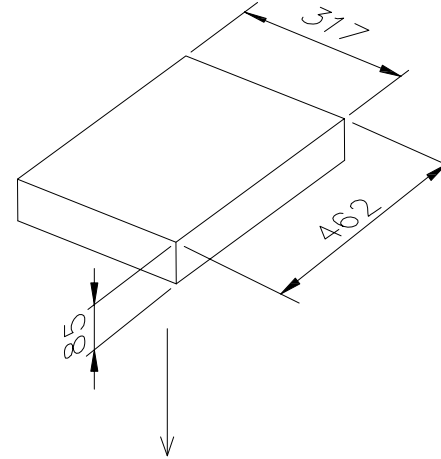

OUTER BOX×1 (5500PCS)

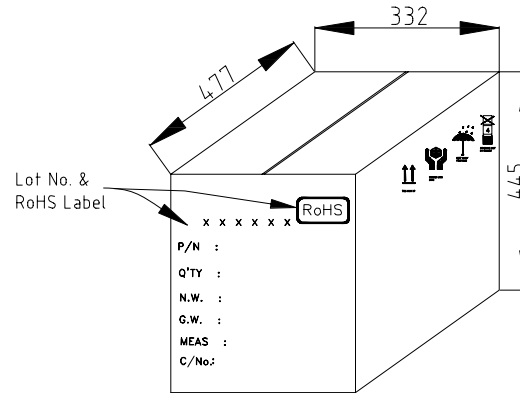

Q'TY/PCS		
OUTER BOX	INNER BOX	TRAY
5500	1100	110

REV. DATE & DRN
1.0 03/02/09 - CHC
PACKAGING DRAWING ADDED

	THIRD ANGLE	Unstated .X .XX	Tolerances: ±0.20 ±0.10	Material SEE NOTE
Drawn: CHC		ANGLES ±1°		
App'd: XXX	Title: PACKAGING			NOT TO SCALE
Date: 03 FEB '09	Revision: 1.0			Unit: mm

www.gradconn.com

THIS DRAWING IS CONFIDENTIAL AND MUST NOT BE
COPIED OR DISCLOSED WITHOUT WRITTEN CONSENT

Type: CH03-BH
CH03-BH0X0-XXT-L
Drawing Number:
Sheet 3 of 3
Drawing © E and O E