



CH03-AJ- SIM CARD HOLDER 6 PINS, SLIDE IN TYPE, OPTIONAL SWITCH

FEATURES

1. GENERAL CHARACTERISTICS
 DIMENSIONS: 15.85L x 16.50W x 3.44H mm
 WEIGHT: APPROX. 0.70±0.2g
 CONTACT PRINCIPLE: FRICTION TECHNOLOGY
 OPERATING POSITION: SHAFT UP / DOWN / HORIZONTAL
 MOUNTING SYSTEM: SMT TYPE OPTIONAL POST
 DURABILITY: 5,000 CYCLES MIN.

2. MECHANICAL CHARACTERISTICS
 INSULATION MATERIAL: THERMOPLASTIC, UL 94V-0
 CONTACT MATERIAL: PHOSPHER BRONZE
 CONTACT PLATING : GOLD FLASH OVER NICKEL
 METAL SHELL MATERIAL: SUS304

3. ELECTRICAL CHARACTERISTICS
 CONTACT RESISTANCE: 50m OHMS TYP. 100m OHMS MAX.
 INSULATION RESISTANCE:> 1000M OHMS / 500V DC
 SWITCH TYPE: BLADE
 RATED CURRENT: 1A MAX.
 RATED VOLTAGE: 50V MAX.
 WITHSTANDING DIELECTRIC VOLTAGE: 500V AC R.M.S. FOR 1 MINUTE

4. SOLDERABILITY
 WAVE: NOT APPLICABLE
 IR REFLOW: 250°C, 5 SEC. MAX.
 MANUAL SOLDERING: 360°C, 3 SEC. MAX.

5. ENVIRONMENTAL CHARACTERISTICS
 OPERATING TEMPERATURE: -40°C ~ +85°C
 OPERATING HUMIDITY: 10% ~ 95% RH
 STORAGE TEMPERATURE: -40°C ~ +85°C
 STORAGE HUMIDITY: 10% ~ 95% RH
 THERMAL SHOCK: -40°C ~ +85°C, 5 CYCLES
 DAMP HEAT: 40°C, 90% RH, 240HR
 SALT-MIST: 35°C, 5% NaCl, 24HR

NOTES:
 1. ACCEPTABLE SIM CARD SIZE SHOULD MEET GSM 11.11 SPECIFICATION REQUIREMENT.
 2. PACKAGING: 700PCS/REEL.

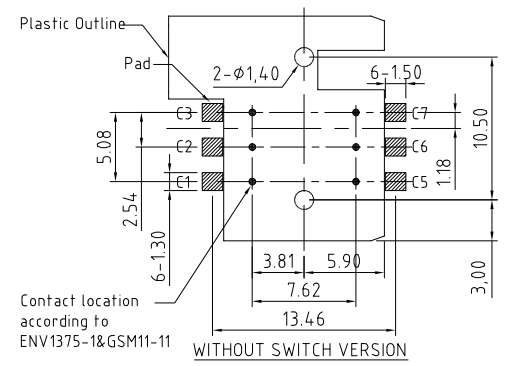
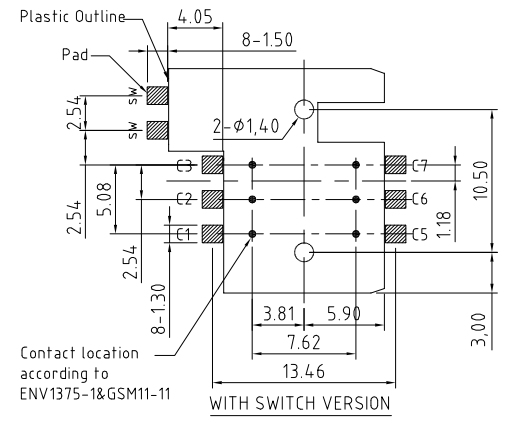
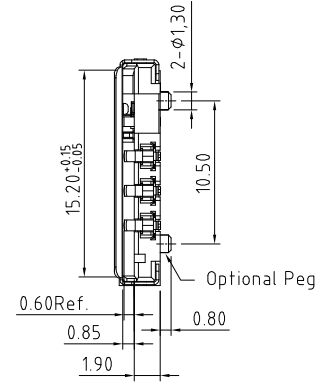
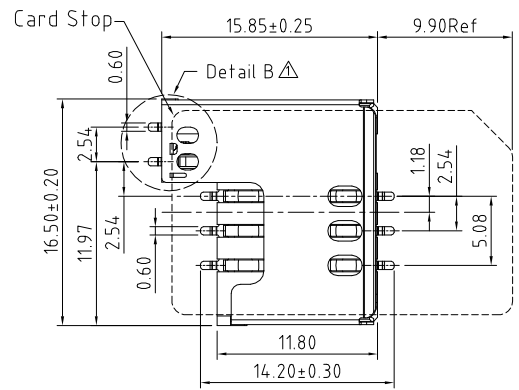
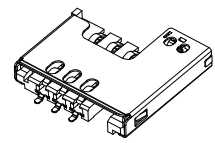
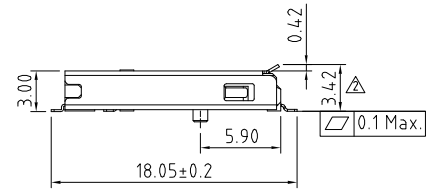

DETAIL B:

Switch Type A (Normally Open) Switch Type B (Without Switch) Switch Type C (Normally Closed)

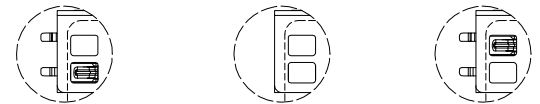

Electric Function	Defect Switch
Without Card	Open
Card Inserted	Closed

Electric Function	Defect Switch
Without Card	Closed
Card Inserted	Open

HOW TO ORDER

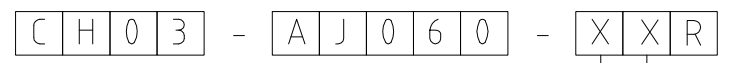

SWITCH OPTIONS:
 A = WITH SWITCH (NORMALLY OPEN)
 B = WITHOUT SWITCH
 ΔC = WITH SWITCH (NORMALLY CLOSED)

LOCATING PEG OPTIONS:
 ΔA = WITH PEG
 B = WITHOUT PEG

Rev. Date & Dwn. 10 17/07/11 - NYW Release.
 11 27/06/12 - NYW Design modification.
 Add normally closed switch option.
 Add with locating peg option.
 12 14/07/12 - NYW Add overall height.
 13 15/07/16 - NYW Design change to have full metal cover.

Scale: 2.5:1	THIRD ANGLE	Unstated Tolerances: X ±0.35 X ±0.25 XX ±0.15 XXX ±0.10	Material SEE NOTE
Drawn: NYW			
App'd: XXXX	Title SIM CARD ACCEPTOR		NOT TO SCALE
Date: 15 JAN. '16	Revision: 1.3		Unit: mm

THIS DRAWING IS CONFIDENTIAL AND MUST NOT BE COPIED OR DISCLOSED WITHOUT WRITTEN CONSENT

Type: CH03-AJ
CH03-AJ
Drawing Number:
Sheet 1 of 2
Drawing © E and O E

CH03-AJ : PACKAGING DRAWING

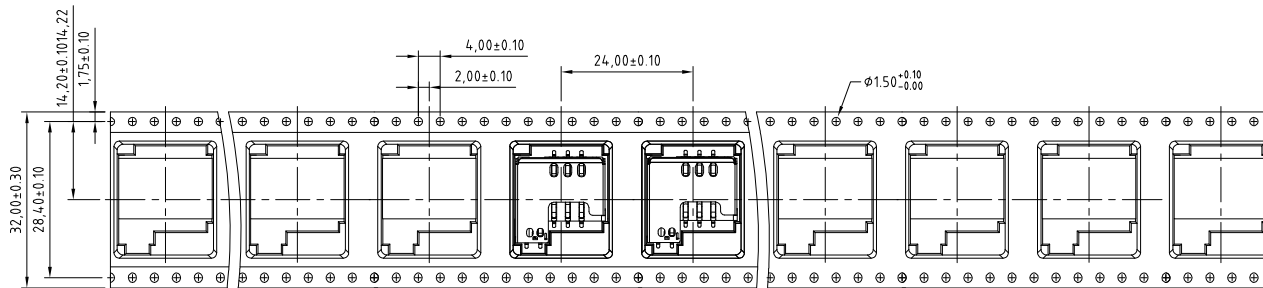
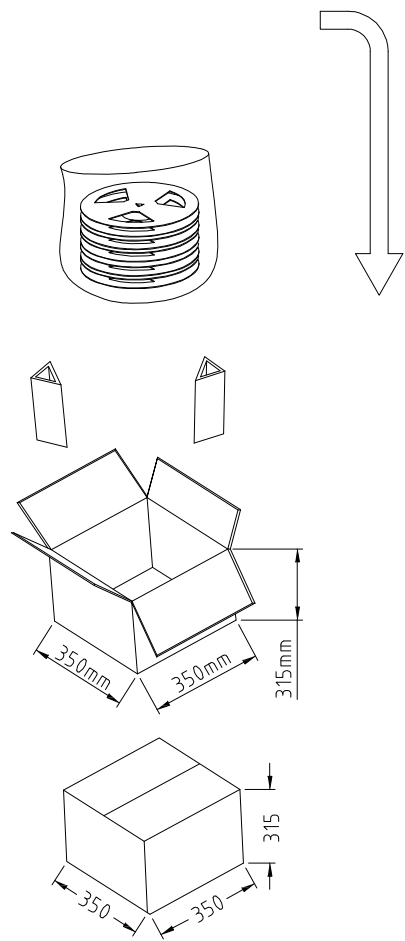

REELING DIRECTION

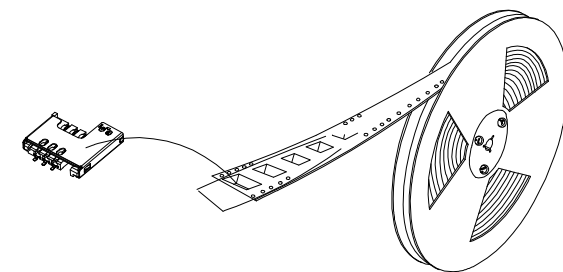
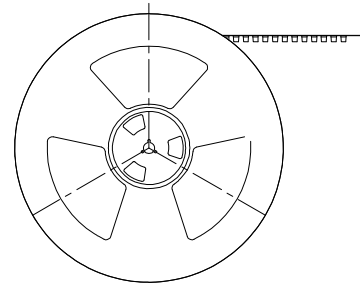

- NOTES:
1. REEL DIA.: 33CM.
 2. 700PCS PER REEL, GROSS WEIGHT: 1.0KG.
 3. 8 REELS PER FULL CARTON, GROSS WEIGHT: 8.0KG.

REV. DATE & DRN	10 08/17/11 - NEW RELEASE	11 05/07/16 - NYW	12 01/15/16 - NYW	Product design change
-----------------	---------------------------	-------------------	-------------------	-----------------------

Scale: NTS	THIRD ANGLE	Unstated Tolerances: 0 Dec Places 1 Dec Places 2 Dec Places 3 Dec Places	Material SEE NOTE
Drawn: NYW			
App'd: XXXX	Title PACKAGING		NOT TO SCALE
Date: 15 JAN. '16	Revision: 11		Unit: mm

www.gradconn.com

THIS DRAWING IS CONFIDENTIAL AND MUST NOT BE COPIED OR DISCLOSED WITHOUT WRITTEN CONSENT

Type: CH03-AJ
CH03-AJ
Drawing Number:
Sheet 2 of 2
Drawing © E and O E