

BB02-HH

CUSTOMER PRODUCT SPECIFICATION SHEET



BB02-HH :- 2.54mm ( 0.1") PIN HEADER SMD TYPE ,SINGLE ROW, RIGHT ANGLE - 02 to 40 CONTACTS

SPECIFICATIONS

CURRENT RATING	3 AMP
INSULATOR RESISTANCE	1000 MEGOHMS MIN.
DIELECTRIC WITHSTANDING	AC 600 V
CONTACT RESISTANCE	20 m OHMS MAX.
OPERATING TEMPERATURE	-40°C TO +105°C
CONTACT MATERIAL	BRASS
INSULATOR MATERIAL	THERMOPLASTIC, UL 94V-0 STANDARD NYLON 6T
PLATING	GOLD, TIN OR SELECTIVE OVER 30-50U" NICKEL
SOLDERABILITY	IR REFLOW: 260°C FOR 10 SEC MANUAL SOLDER: 350°C FOR 3-5 SEC

NOTES:

1. MAX. NUMBER OF CONTACTS ALLOWED FOR TAPE & REEL PACKAGING:  
32 CONTACTS.

MATES WITH :-

BB02-JB	BB02-JJ
BB02-JC	BB02-JL
BB02-JE	BB02-JS
BB02-JF	BB02-JT
BB02-JG	BB02-KR

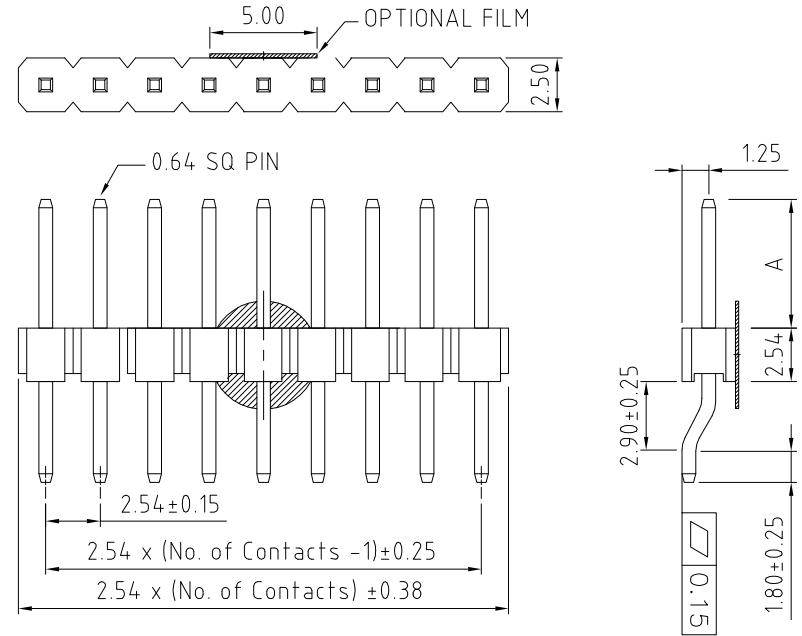

HOW TO ORDER

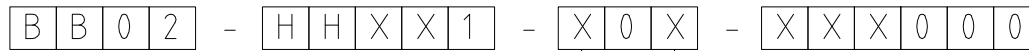

NO. OF CONTACTS:  
02 TO 40

CONTACT PLATING OPTIONS:  
 K = GOLD FLASH (STANDARD)  
 A = 10U" GOLD ON CONTACT/GOLD FLASH ON TAIL  
 B = 15U" GOLD ON CONTACT/GOLD FLASH ON TAIL  
 C = 30U" GOLD ON CONTACT/GOLD FLASH ON TAIL  
 T = BRIGHT TIN  
 M = MATT TIN  
 D = GOLD FLASH ON CONTACT/BRIGHT TIN ON TAIL  
 E = 10U" GOLD ON CONTACT/BRIGHT TIN ON TAIL  
 F = 15U" GOLD ON CONTACT/BRIGHT TIN ON TAIL  
 G = 30U" GOLD ON CONTACT/BRIGHT TIN ON TAIL

PACKAGING OPTIONS:  
 2 = BOX (standard)  
 6 = TAPE & REEL  
 7 = TAPE & REEL & FILM  
 (see note 1)

PIN LENGTH A (1/10mm)  
 PLEASE SPECIFY PIN  
 LENGTH REQUIRED  
 I.E. 2.5mm = 025  
 STANDARD = 060  
 TOL.: ±0.25MM

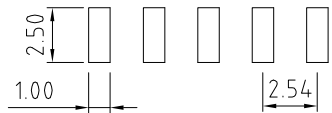

RECOMMENDED PCB LAYOUT  
(TOLERANCE: ±0.05)

REV.	DATE & DRN
10	06/07/05 - NYW RELEASE
11	15/08/06 - NYW DRAWING MODIFICATION
12	05/06/08 - CHC PLATING MODIFICATION
13	17/07/09 - NYW ADD FILM DRAWING REMOVE PACK OPTION 8 AND DRAWING MODIFICATION
14	23/07/13 - NYW ADD NOTE 1.

Scale: 4:1	THIRD ANGLE	Unstated Tolerances: X ± 0.30 X ± 0.25 XX ± 0.15 XXX ± 0.10	Material SEE NOTE
Drawn: CHC			
App'd: XXXX	Title: PIN HEADER		NOT TO SCALE
Date: 23 OCT. '13	Revision: 14		Unit: mm

**GradConn**  
www.gradconn.com

© THIS DRAWING IS CONFIDENTIAL AND MUST NOT BE COPIED OR DISCLOSED WITHOUT WRITTEN CONSENT

Type: BB02-HH
BB02-HH
Drawing Number:
Sheet 1 of 1
Drawing © E and O E