



CABLE 084 RF: RF CABLE ASSEMBLY, IPEX MHF + 1.13 CABLE + STRIP / TIN

SPECIFICATIONS

1. I-PEX MHF PLUG (20278-112R-13)
2. 1.13MM MIT COAXIAL CABLE (BLACK)
3. FLEXIBLE COPPER WIRE, DIAMETER: 0.5MM.

**USAGE PRECAUTIONS: CABLES USING 'MICRO' COAX ARE DELICATE:**  
 (i) HANDLE WITH CARE.  
 (ii) DO NOT TWIST; APPLY EXCESSIVE FORCES OR SHARP BENDS TO THE CABLE. DO NOT FORCEFULLY DEFORM WIRES.  
 (iii) CONSULT CONNECTOR MANUFACTURER'S DATASHEETS FOR DETAILED NOTES ON HANDLING INSTRUCTIONS.

NOTES:

1. STRIP DIMENSION A / B / C STANDS FOR  
 A = CENTRE CONDUCTOR  
 B = INSULATOR  
 C = BRAID.
2. INSERTION LOSS TEST REPORT IS NOT AVAILABLE.
3. THIS IS OUR STANDARD OFFERING, SPECIAL DESIGNS ARE AVAILABLE, INCLUDING CUSTOM TOLERANCES AND SPECIAL BRAID TINNING DESIGNS. PLEASE CONTACT GRADCONN FOR MORE INFORMATION.
4. CENTRE CONDUCTOR OF COAX CABLE IS TINNED. LENGTH OF TINNED COPPER WIRE IS SOLDERED TO THE BRAID/SHIELD OF THE COAX CABLE WHICH ALLOWS SOLDERING TO PCB.

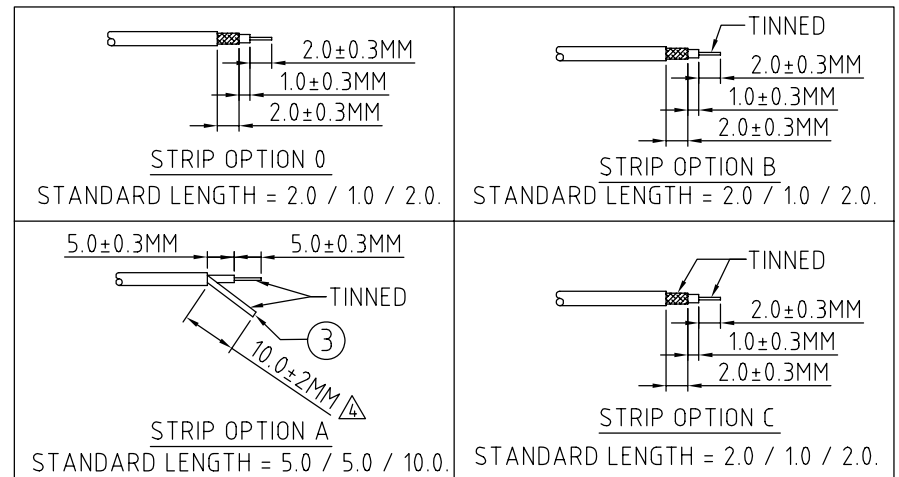
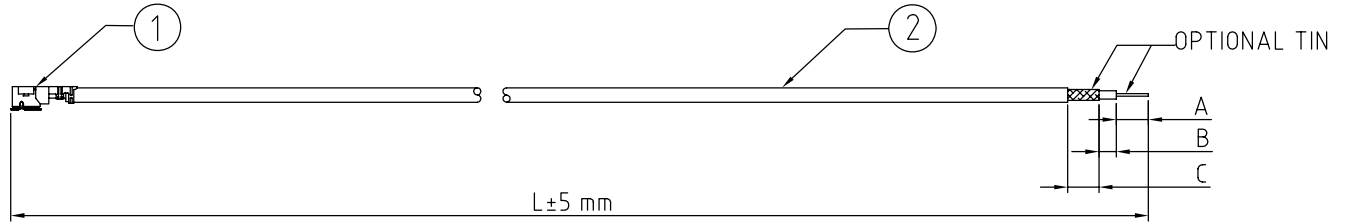

HOW TO ORDER

CABLE 084 RF - X X X - X.X / X.X / X.X - X

"L" LENGTH IN MM  
 eg: 100MM = 100  
 (MIN. 025 - MAX. 400  
 STANDARD : 100, 150, 200)

A/B/C STRIP DIMENSION IN MM  
 FOR STANDARD LENGTH PLEASE  
 REFER TO DRAWINGS.  
 (SPECIALS AVAILABLE UPON  
 REQUEST.)

STRIP AND TIN OPTIONS:  
 0 = STRIPPED ONLY, NOT TINNED  
 A = CENTER CONDUCTOR & SOLDERED COPPER WIRE TINNED  
 (SEE NOTE 4 FOR SOLDER TO PCB APPLICATION)  
 B = STRIPPED, END A TINNED  
 C = STRIPPED, END A & C TINNED

REV. DATE & DRN  
 10 26/10/09 - NYW RELEASE  
 11 27/10/09 - NYW REMOVE B STRIP OPTION  
 12 30/10/09 - NYW ADD STRIP OPTIONS B, C  
 13 26/11/09 - NYW ADD 1 DECIMAL PLACE TO STRIP DIMENSION  
 14 10/07/11 - NYW AMEND TOLERANCE

Scale: NTS	THIRD ANGLE	Unstated .X .XX .XXX ANGLES	Tolerances: ±0.2 ±0.1 ±0.05 ±5	Material SEE NOTE
Drawn: NYW				
App'd: XXX	Title CABLE ASSEMBLY	NOT TO SCALE		
Date: 11 JUL '11	Revision: 1.4	Unit: mm		

www.gradconn.com

THIS DRAWING IS CONFIDENTIAL AND MUST NOT BE COPIED OR DISCLOSED WITHOUT WRITTEN CONSENT

Type: Cable 084 RF
CABLE 084 RF
Drawing Number:
Sheet 1 of 1
Drawing © E and O E